

**Ultracoustic**

# CONTENT

## 1. Hybrid

Fern  
Flute  
Livia  
Myra  
Nero  
Ripple  
Sphaira  
Ultrawood  
Vita  
Zena

## 2. Absorber

Horizon  
Pegasus  
U curve premium  
U Square Premium  
Vivid  
Edge

## 3. Bass Trap

Augustus  
Decimus  
Modal Trap  
Ultra Trap

## 4. Diffusers

Ultra Fuser  
Primo 7  
Optimus  
Magnus  
Wave fuser  
Polycustic

## 5. Colours & Textures

## 6. Fixing Guide



## We are Ultracoustic

Ultracoustic is a multi award winning company. We have established ourselves as one of the most dynamic companies in the acoustic manufacturing and acoustic solutions industry. Ultracoustic offers a range of innovative products and services, representing the outcome of years of development, testing and optimization.

Our engineers work in strategic partnership with other industry sections, including science institutes and universities, as well as gaining regular feedback from some of India's leading engineers.

In addition to outstanding performance our products have a revolutionary design and a high level of fire retardancy which makes them suitable for use in a variety of venues.

Ultracoustic's mission is simple; Improve the acoustics of our everyday surroundings, be it a residential setting a home cinema or a critical listening room, we offer solutions in an affordable and accessible way.

## Why Ultracoustic



Sustainable

---



Anti Warping

---



Fire Safety

---



Fast Installation

---

# Fern

Simple and elegant mid Frequency Absorber

Hybrid

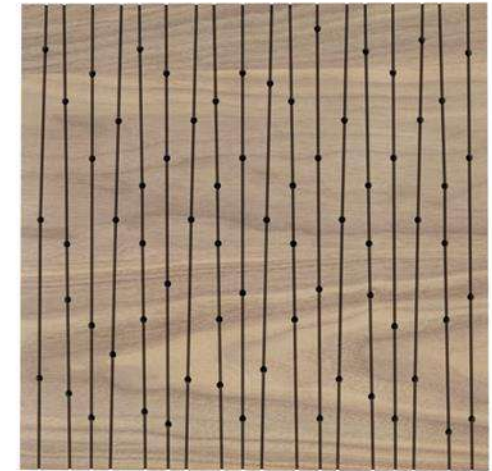
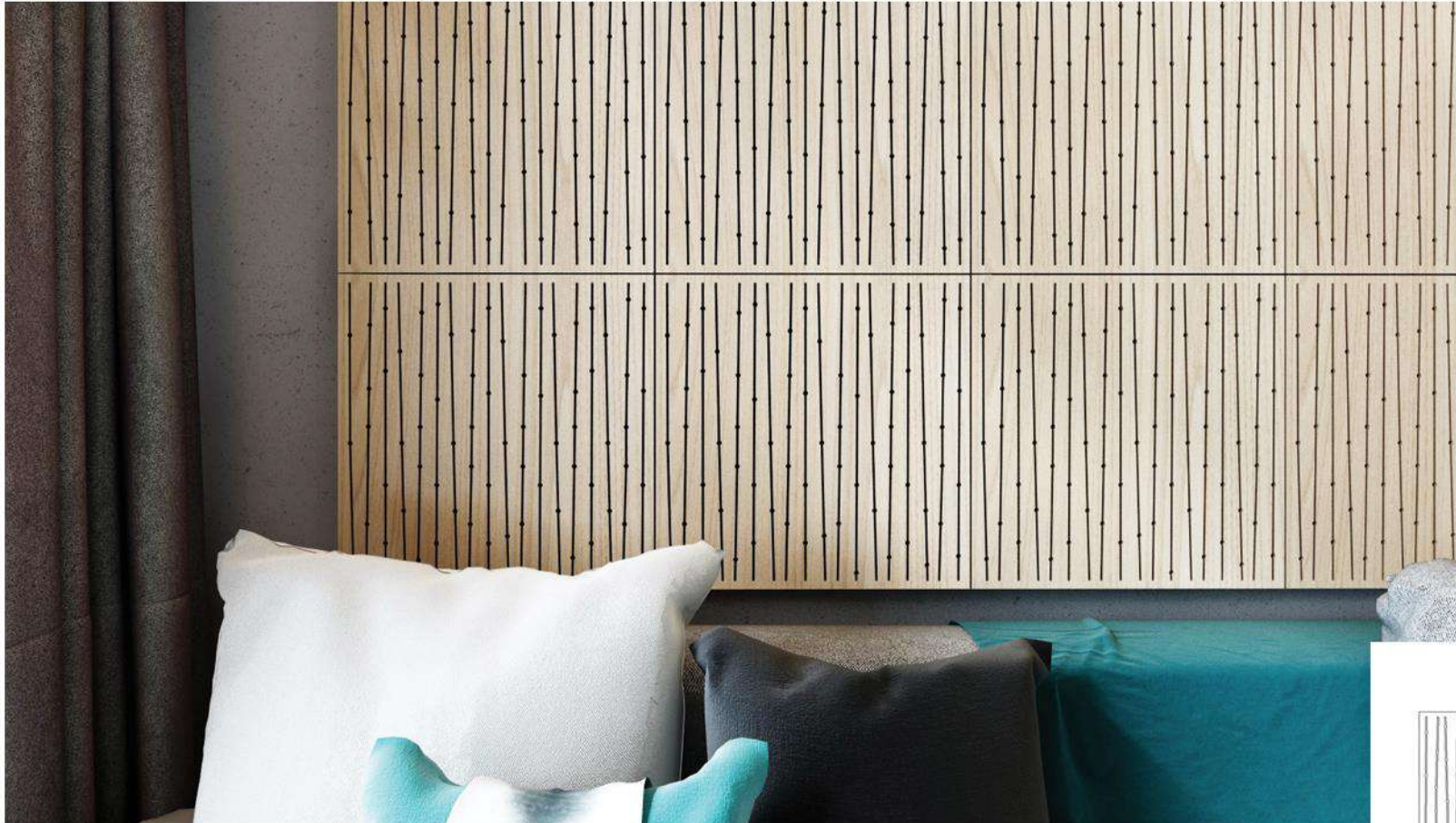

Absorption range: 200Hz to 2000Hz.  
Acoustic Class = NRC 0.65  
Finishes: Wood | Solid Color | Metallic

Installation systems:  
Glue | Grid | Clip

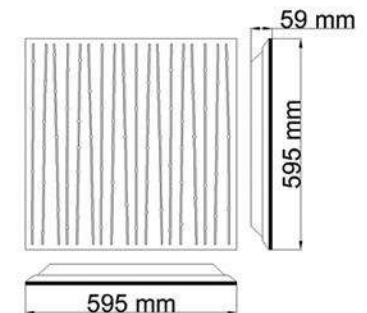

Fern hybrid acoustic panels are designed to absorb medium frequencies. It absorbs maximum in mid frequency range whereas diffuses high frequency range. Fern has a simple yet elegant design which will only add to décor.

# Flute

Simplistic design with maximum efficiency.

Hybrid

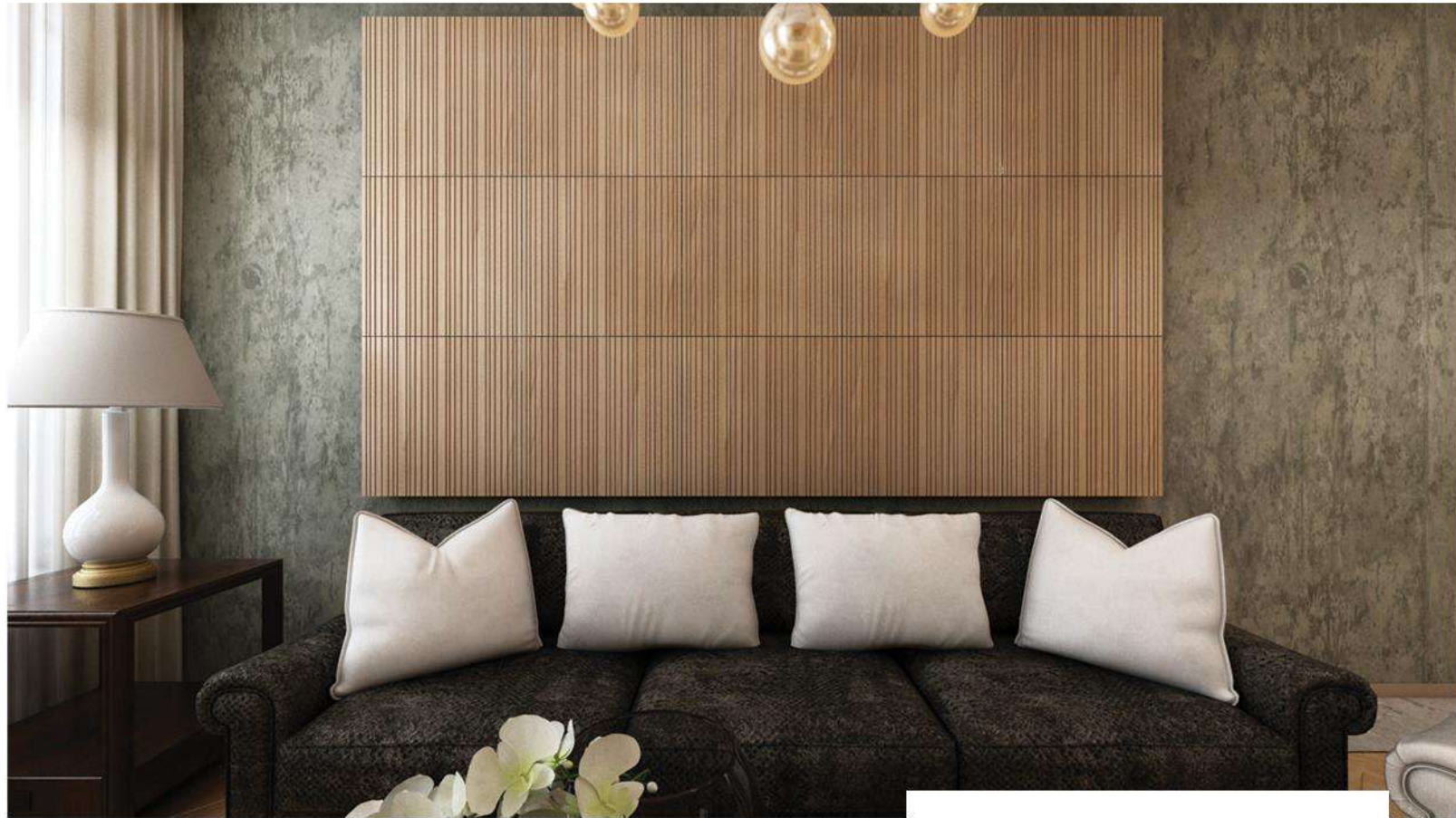

Absorption range: 250Hz to 5000Hz.  
Acoustic Class = NRC 0.70  
Finishes: Wood | Solid Color | Metallic

Installation systems:  
Glue | Grid | Clip

A timeless design, flute is a hybrid absorber which is very efficient in absorbing mid frequency and scattering some high frequency. Flute acoustic panels are perfect for any site where reverberation is an issue.

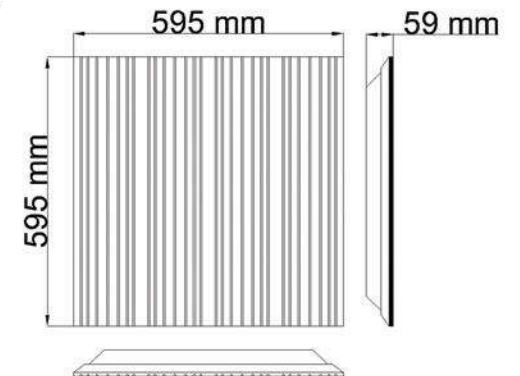

# Livia

A Hybrid Panel with Multiple design effects.

Hybrid

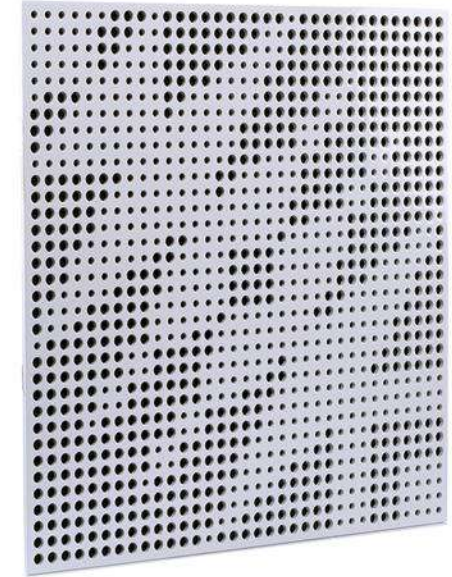
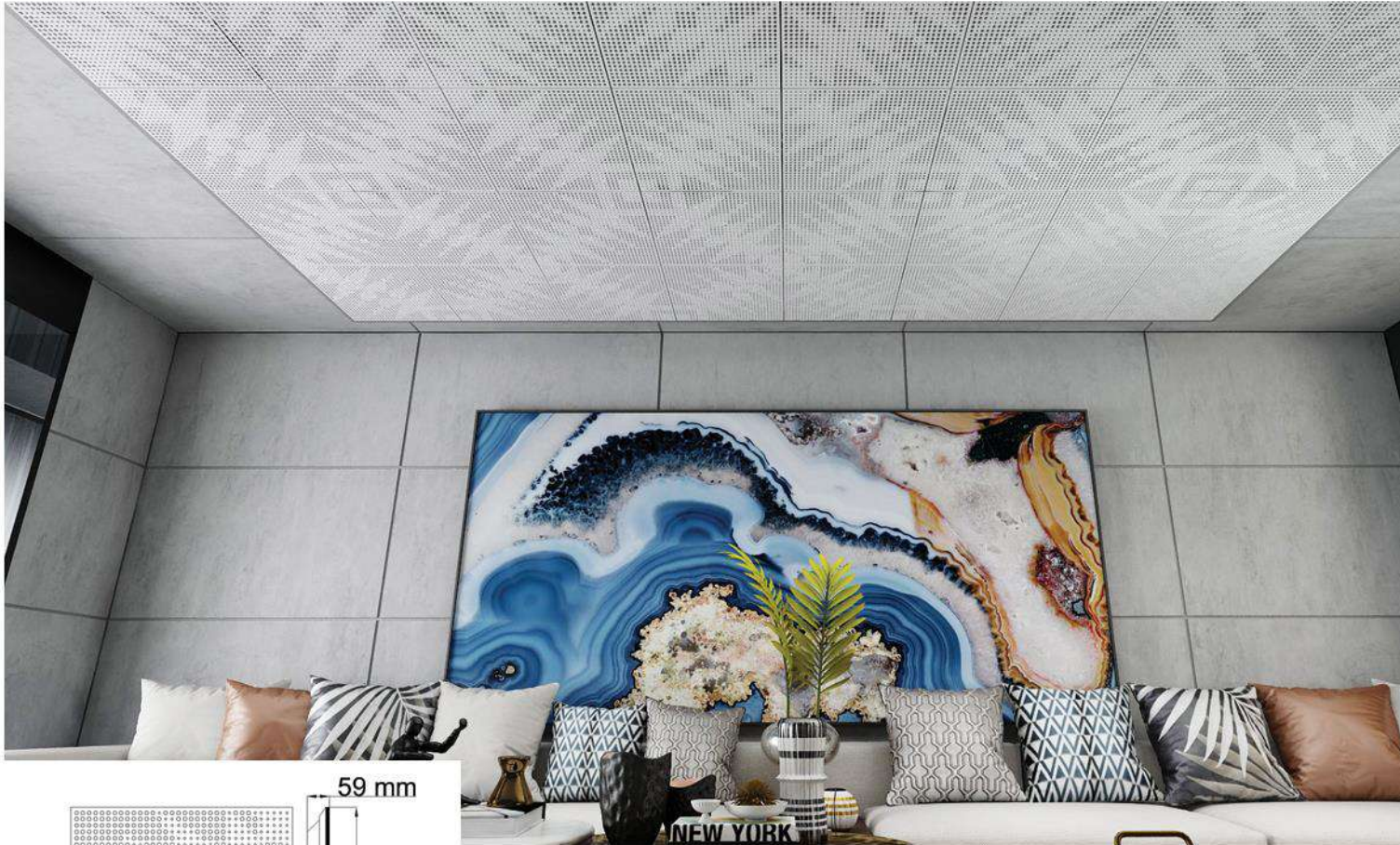

Absorption range: 250Hz to 5000Hz.  
Acoustic Class = NRC 0.75  
Finishes: Wood | Solid Color | Metallic

Installation systems:  
Glue | Grid | Clip

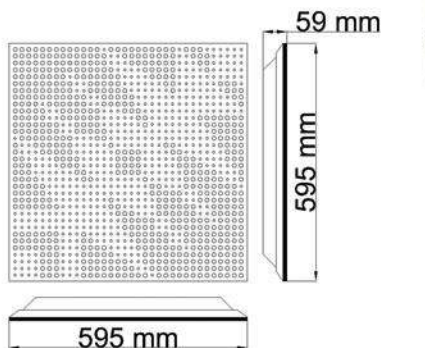

Livia hybrid acoustic panels are designed to work at high & medium frequencies. It absorbs maximum in mid frequency range whereas scattering some in high frequency range. Livia's unique design helps create a 3D effect on the panel's surface, the panel can be arranged in multiple stylish designs helping you create a unique and personalized ambience for your room.

# Myra

High Performance Absorber / Diffuser



Absorption range: 200Hz to 4000Hz.  
Acoustic Class = NRC 0.65  
Finishes: Wood | Solid Color | Metallic

Installation systems:  
Glue | Grid | Clip



Featuring a sharp slotted design that is acoustically tuned for spreading energy uniformly while absorbing the unwanted reflections. The Myra panels are manufactured using the most premium wood and our proprietary acoustic foam, the panels absorb and scatter energy simultaneously.

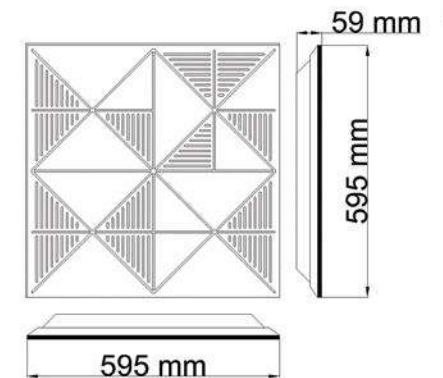

# Nero

A Hybrid panel with multi pattern effect

Hybrid

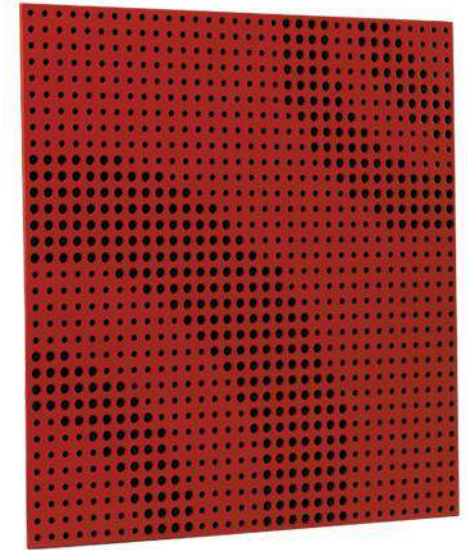

Absorption range: 250Hz to 5000Hz.  
Acoustic Class = NRC 0.75  
Finishes: Wood | Solid Color | Metallic

Installation systems:  
Glue | Grid | Clip

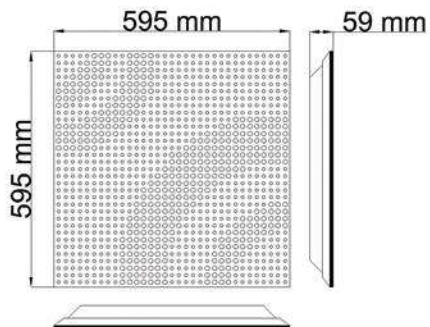

Nero hybrid acoustic panels are designed to control problems at high & medium frequencies, in turn excessive reverberation. Nero's unique design helps create a 3D effect on the panel's surface, the panel can be arranged in multiple stylish designs helping you create a unique and personalized ambience for your room.

## Ripple

Ultra-luxurious Panel for absorption and diffusion.

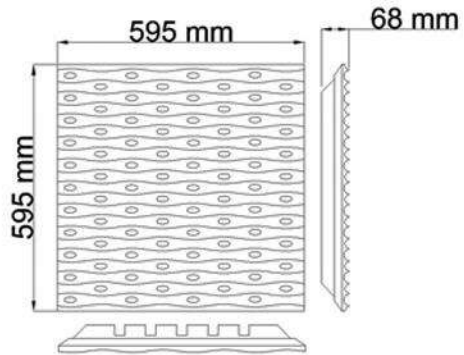

Absorption range: 250Hz to 5000Hz.  
Acoustic Class = NRC 0.75  
Finishes: Solid Color | Metallic

Installation systems:  
Glue | Grid | Clip



Ripple is a smooth, glossy and curvy panel giving an ultra-luxurious feeling to acoustic treatment. Ripple is a hybrid panel which absorbs in mid and high frequency range whilst scattering some high frequencies simultaneously.

# Sphaira

Elegant Acoustic panel

Hybrid

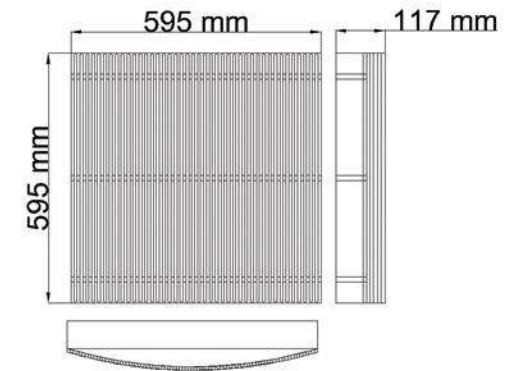

Absorption range: 250Hz to 5000Hz.  
Acoustic Class = NRC 0.80  
Finishes: Wood | Solid Color | Metallic

Installation systems:  
Clip



Sphaira is an acoustic panel with timeless and elegant design. It absorbs maximum sound in mid frequency range and therefore these panels are perfect for any site.

# Ultra Wood

Hybrid panel with elegance.

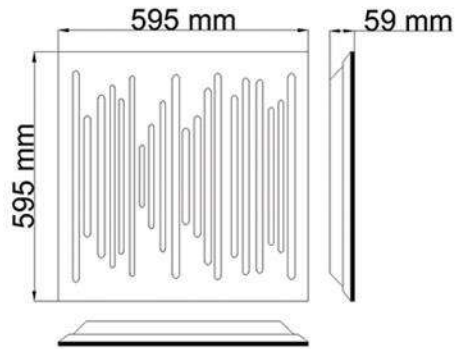

Absorption range: 200Hz to 4000Hz.  
Acoustic Class = NRC 0.88  
Finishes: Wood | Solid Color | Metallic

Installation systems:  
Glue | Grid | Clip

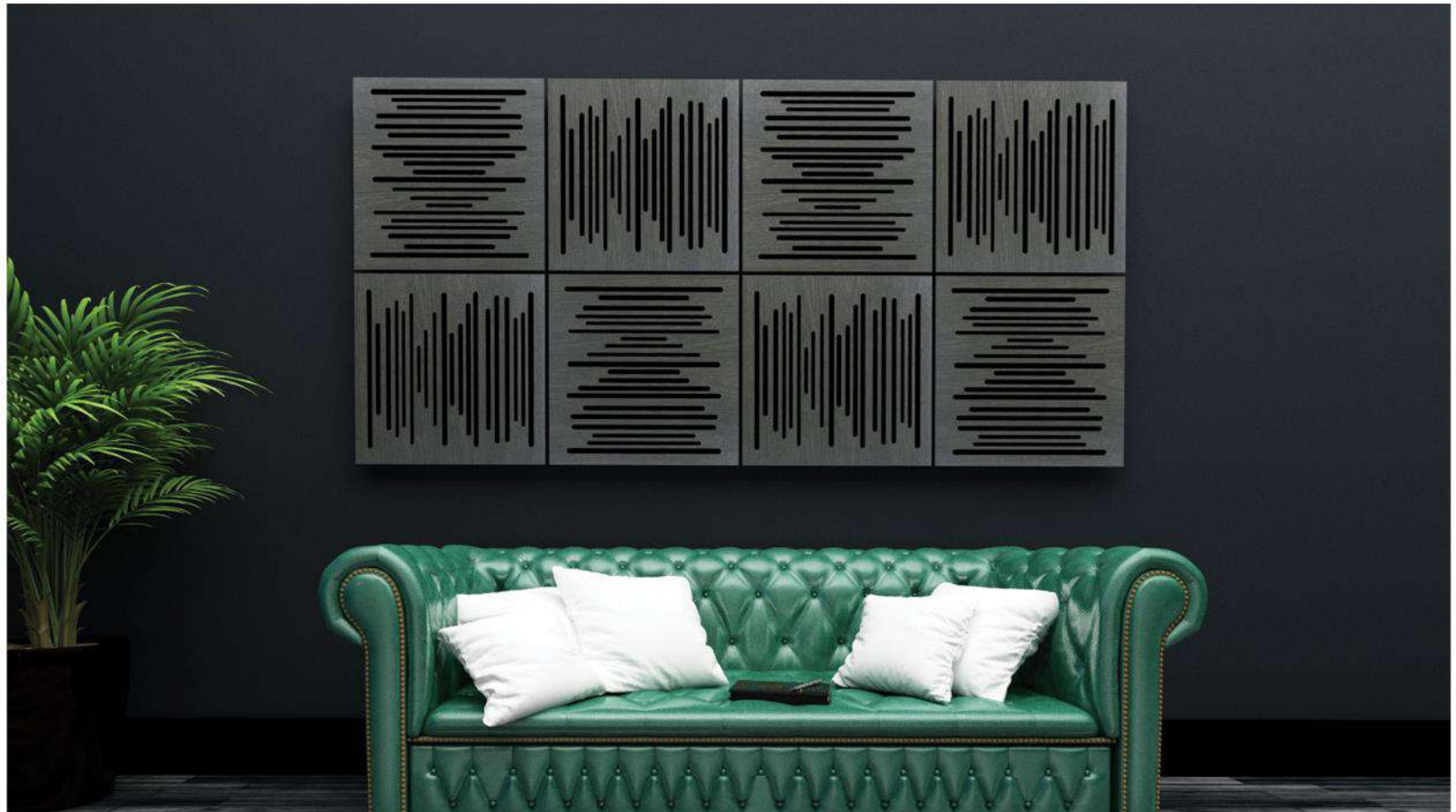

Ultra Wood acoustic panels are designed on the (MLS) Maximum length sequences. Featuring a sharp slotted design that is acoustically tuned for spreading energy uniformly while absorbing the unwanted reflections. The Ultra Wood panels are manufactured using the most premium wood and our proprietary acoustic foam, the panels absorb and scatter energy simultaneously.

# Vita

Multi patterned offering unlimited design solutions.

Hybrid

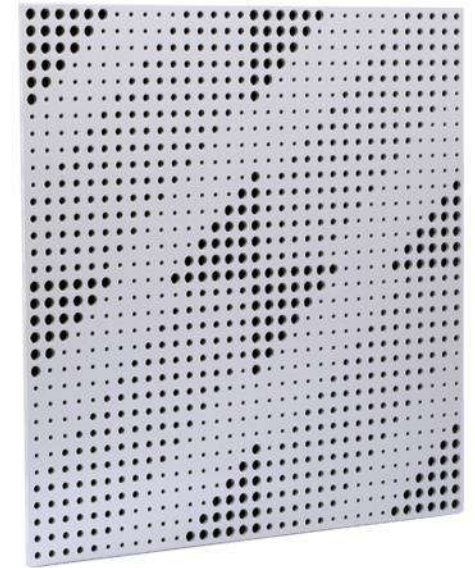
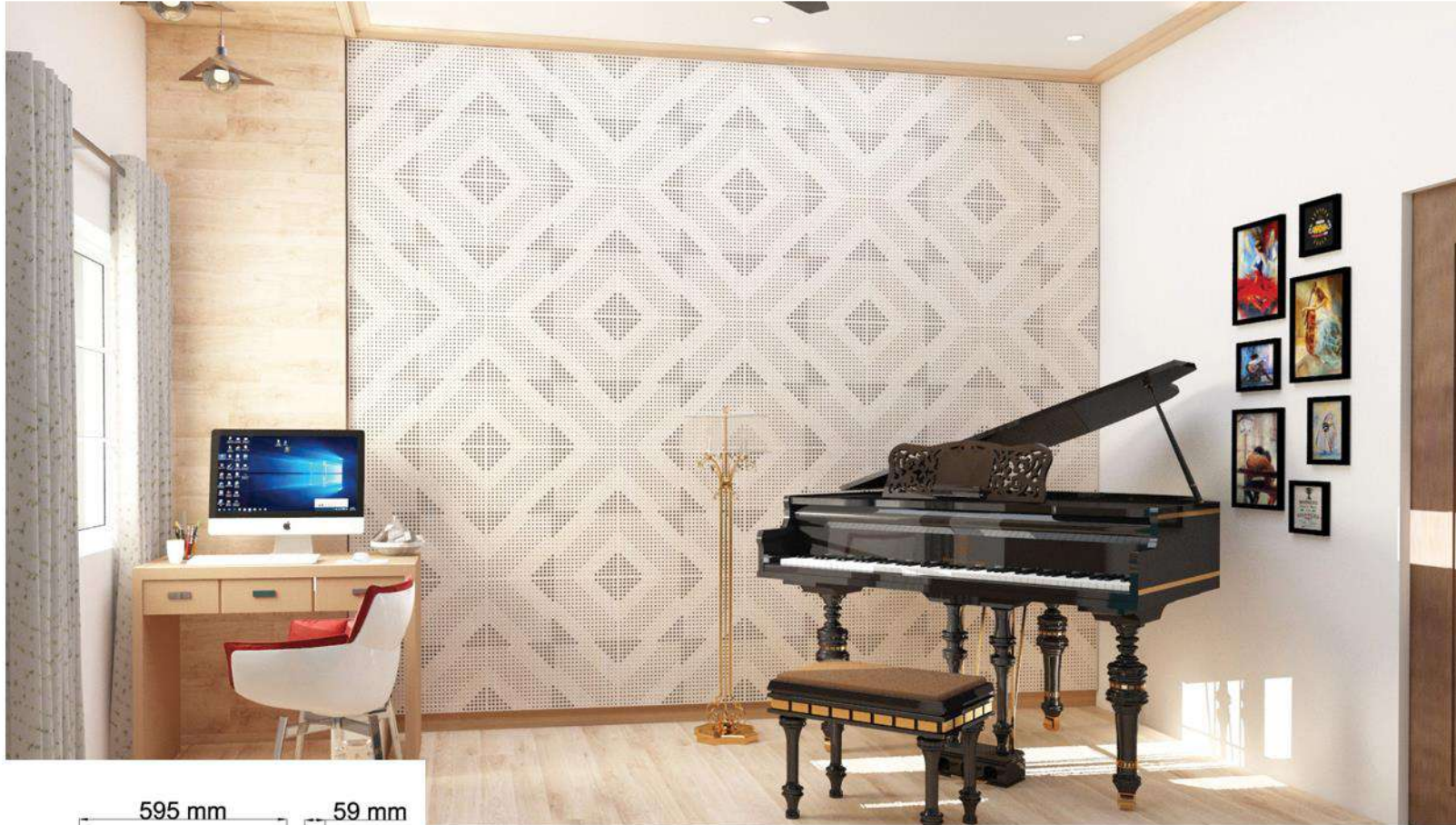

Absorption range: 250Hz to 5000Hz.  
Acoustic Class = NRC 0.70  
Finishes: Wood | Solid Color | Metallic

Installation systems:  
Glue | Grid | Clip

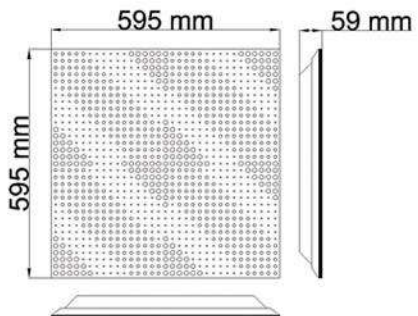

Vita is a hybrid panel meaning it will absorb and diffuse frequencies simultaneously. Vita is designed to absorb in mid frequencies and diffuse at high frequencies, giving an overall acoustic balance in a room. The Vita sports a multi pattern design offering the best in performance and aesthetics.

# Zena

Hybrid Panel for absorption and diffusion.

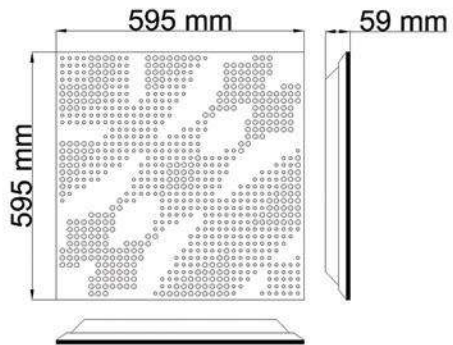

Absorption range: 125Hz to 4000Hz.  
Acoustic Class = NRC 0.70  
Finishes: Wood | Solid Color | Metallic

Installation systems:  
Glue | Grid | Clip

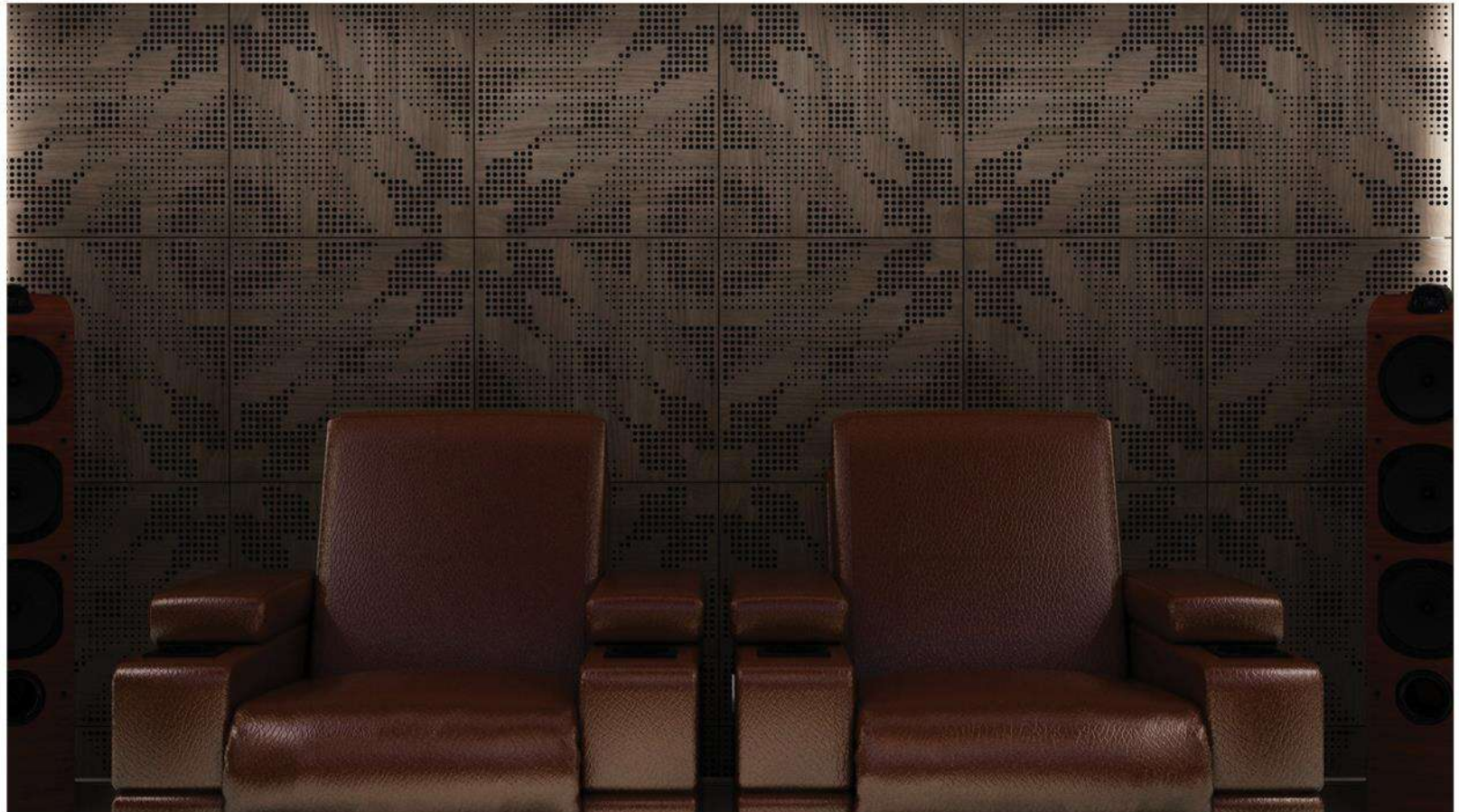

Zena is a high performance acoustic panel designed to control early reflections and absorb low to medium frequencies and scatter high frequencies. The Zena's multi pattern design offers only the best in performance and aesthetics.

# Horizon Pro

Classic Panel for broadband absorption

Absorber

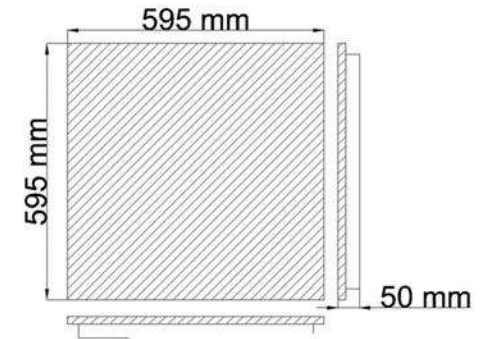

Absorption range: 200Hz to 8000Hz.  
Acoustic Class = NRC 0.97  
Finishes: Standard Fabric | Suede

Installation systems:  
Impaler | Glue | Grid

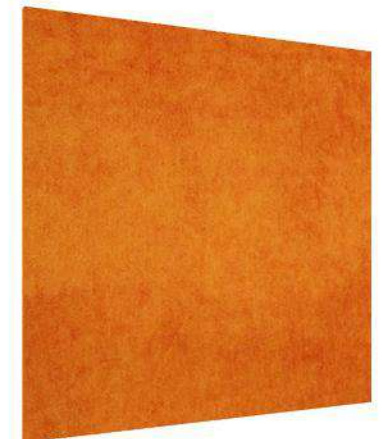

Multipurpose Horizon acoustic panels are designed to reduce and control primary & secondary reflections, enhancing speech & sound intelligibility. Horizon is a broadband absorber implying that it absorbs a very broad range of frequencies very efficiently.

# Pegasus

Luxurious Panel for mid-high frequency absorption

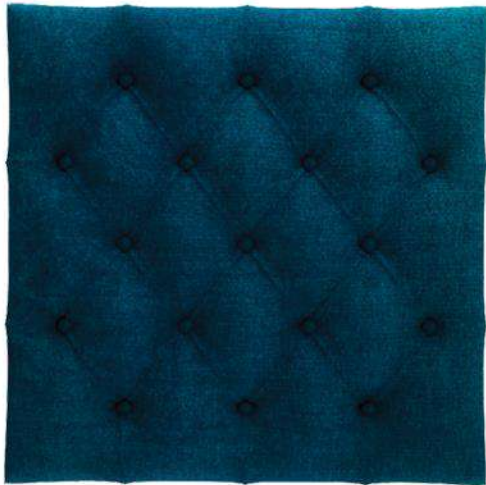

Absorption range: 250Hz to 5000Hz.  
Acoustic Class = NRC 0.80  
Finishes: Suede

Installation systems:  
Glue | Grid



Pegasus an acoustic panel is designed to give that ultra-luxurious feeling. A classic design, perfect for any application where absorption is required. Pegasus acoustic panels can be easily installed on walls .

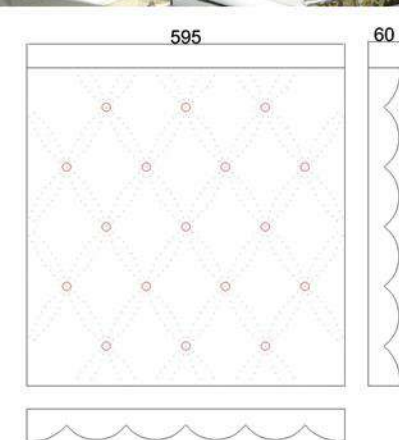

# U Curve Premium

Wavy panel for broadband absorption

Absorber



Absorption Range: 250Hz to 5000Hz  
Acoustic Class = NRC 0.85  
Finishes: Suede

Installation systems:  
Glue | Clip

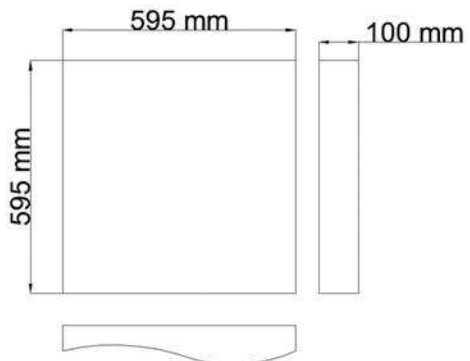

U Curve Premium's unique wave design gives a continuous pattern, designed to absorb reflections and excessive reverberation. Manufactured using premium materials and carefully covered with suede finish, the U Curve Premium shows great performance between mid to high frequencies.

## U Square Premium

Premium Panel for broadband absorption.

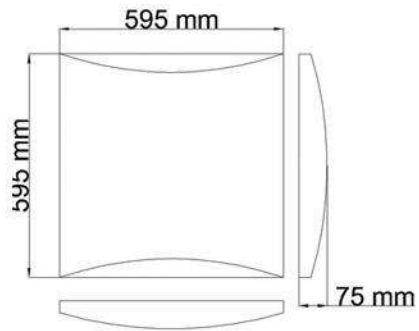

Absorption Range: 250Hz to 5000Hz  
Acoustic Class = NRC 0.88  
Finishes: Micro Suede

Installation systems:  
Glue | Clip



Primarily designed to absorb reflections, excessive reverberation. Manufactured using premium materials and carefully covered with suede finish, the U Square Premium shows great performance between mid to high frequencies.

# Vivid

Small Broadband Absorbers

## Absorber

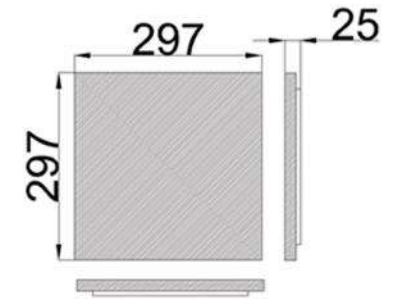

Absorption range: 250 Hz to 5000 KHz.  
Acoustic Class = NRC 0.80  
Finishes: Standard Fabric | Micro Suede

Installation systems:  
Impaler | Glue | Grid

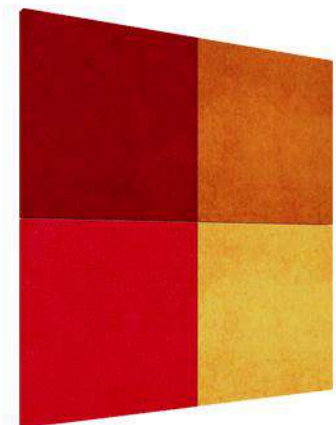

Vivid acoustic panels are small panels with a big impression. Like their successor Horizon Pro panels, Vivid are designed to absorb primary & secondary reflections and control overall reverberations which enhances speech & sound intelligibility.

## Edge Pro

Elegant Panel for mid-high frequency absorption

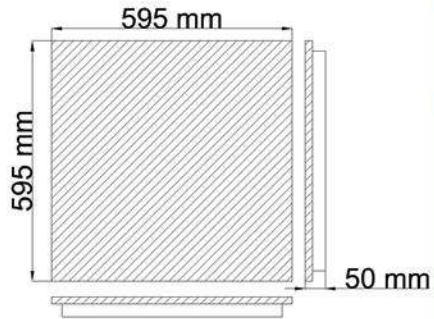

Absorption range: 250Hz to 5000Hz.

Acoustic Class = NRC 0.80

Finishes: Standard Fabric | Suede

Installation systems:

Glue | Grid

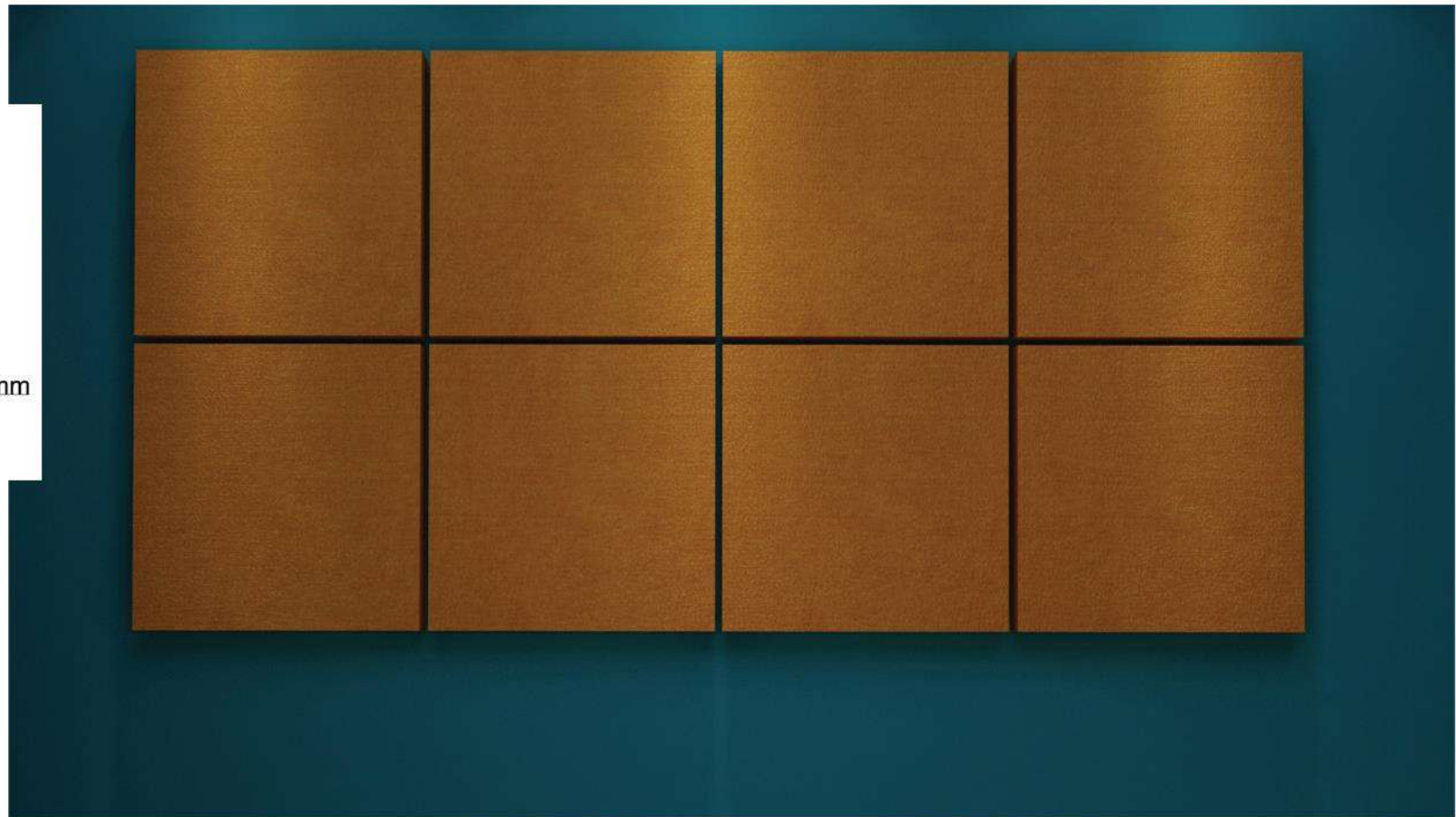

Edge acoustic panels are designed to reduce reverberation in a room enhancing speech & sound intelligibility. Edge is the same in design as Horizon but the acoustic core is different. Edge acoustic panels can be easily installed on walls or ceilings.

# Augustus

Corner Bass Trap for low frequency absorption

## Bass Trap



Absorption range: 63 Hz to 5000 Hz.  
Bass Trap Type = Pressure & Velocity  
Finishes: Wood & Fabric

Installation systems:  
Clip | Cleat

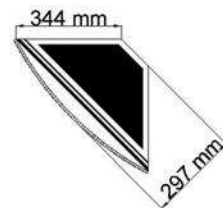
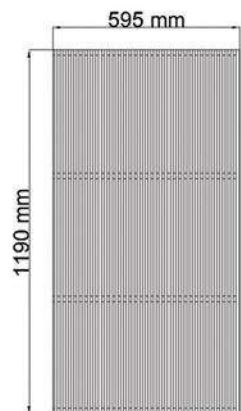

The Augustus Corner Bass Trap is designed to mount and fit in any corner to help control excessive low frequency build-up in studios and listening rooms by providing an easy to mount solution that fits in any corner. The Augustus Bass Trap uses a unique proprietary membrane to maximize its efficiency.

# Decimus

Great for low frequency absorption.



Absorption range: 40 Hz to 1000 Hz.  
Bass Trap Type = Pressure & Velocity  
Finishes: Wood & Fabric

Installation systems:  
Clip | Cleat



The latest in low frequency absorption is the Decimus Corner Bass Trap that integrates the elegance and the tunability of a bass trap that is corner mounted. Decimus is a velocity and pressure bass trap which works like a giant resonator, allowing for a much superior and controlled environment.

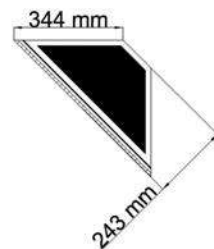
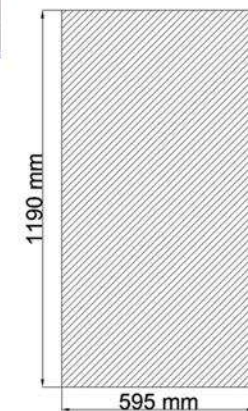

## Modal Trap

High Performance Bass Trap



Absorption range: 40Hz to 5000Hz.  
Finishes: Wood & Fabric

Installation systems:  
**Cleat**

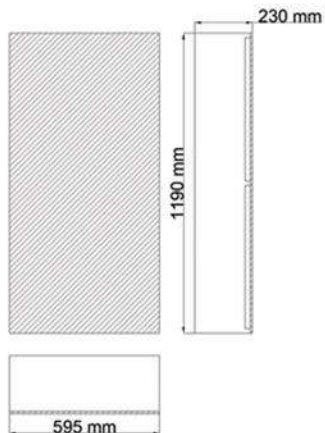

Tuned to 40Hz the Modal Trap is a heavy weight when it comes to ultra-low frequency absorption. The Modal Trap also helps in eliminating flutter echo, standing waves and tightens up room acoustics. The end result effectively expands the size of the listening sweet spot while reducing ear fatigue, and makes the Modal Trap particularly valuable for those working in small to medium sized rooms.

# Ultra Trap

High Performance Bass Trap

## Bass Trap

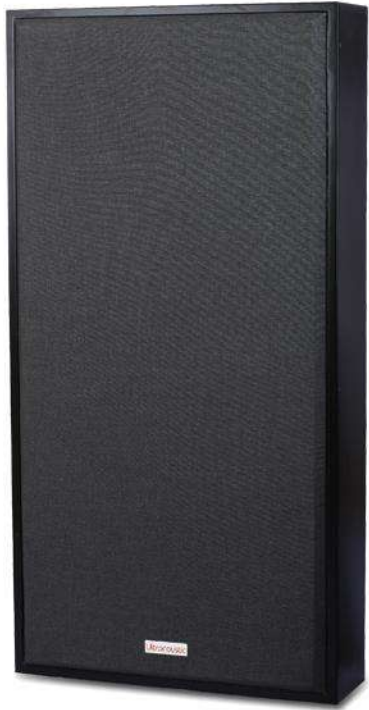

Absorption range: 40Hz to 5000Hz.  
Finishes: Wood & Fabric

Installation systems:  
**Cleat**



Tuned to 40Hz the Modal Trap is a heavy weight when it comes to ultra-low frequency absorption. The Modal Trap also helps in eliminating flutter echo, standing waves and tightens up room acoustics. The end result effectively expands the size of the listening sweet spot while reducing ear fatigue, and makes the Modal Trap particularly valuable for those working in small to medium sized rooms.

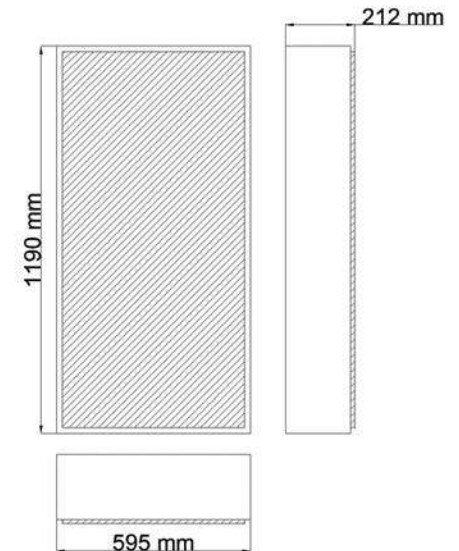

# Ultrafuser

A Two Dimensional Diffuser.

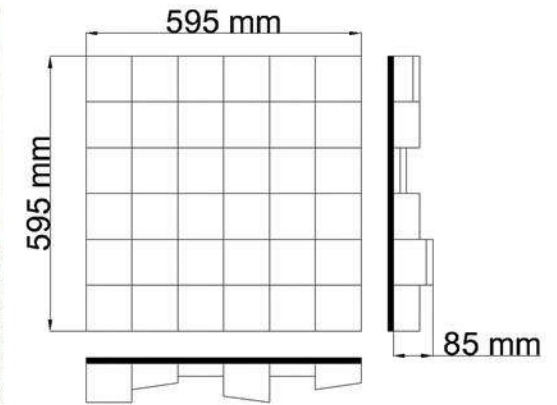

Acoustic Class = Diffuser  
 Diffusion range: 600Hz to 4000Hz.  
 Finishes: Wood | Solid | Metallic

Installation systems:  
 Clip



Ultrafuser diffusers are two-dimensional diffusers designed to scatter sound in two dimensions i.e. from ceiling to floor and from left to right. Ultrafuser reduces image formation and increases liveliness of room thereby improving sound quality and texture. Edgy design with great performance.

## Primo 7

A one Dimensional QRD.

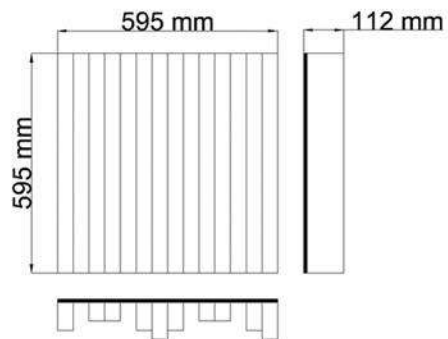

Acoustic Class = Diffuser  
Diffusion range: 700Hz to 4000Hz.  
Finishes: Wood | Solid | Metallic

Installation systems:  
Clip



Primo 7 diffusers are one-dimensional diffusers designed to scatter sound waves in one dimension i.e. from left to right. Primo 7 reduces image formation and increases the liveliness of the room thereby improving sound quality and texture. QRD based design with great performance and can be easily installed on walls or ceilings.

## Optimus

A diffuser to make sound sweeter.

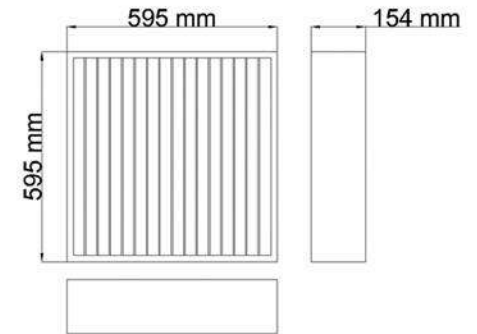
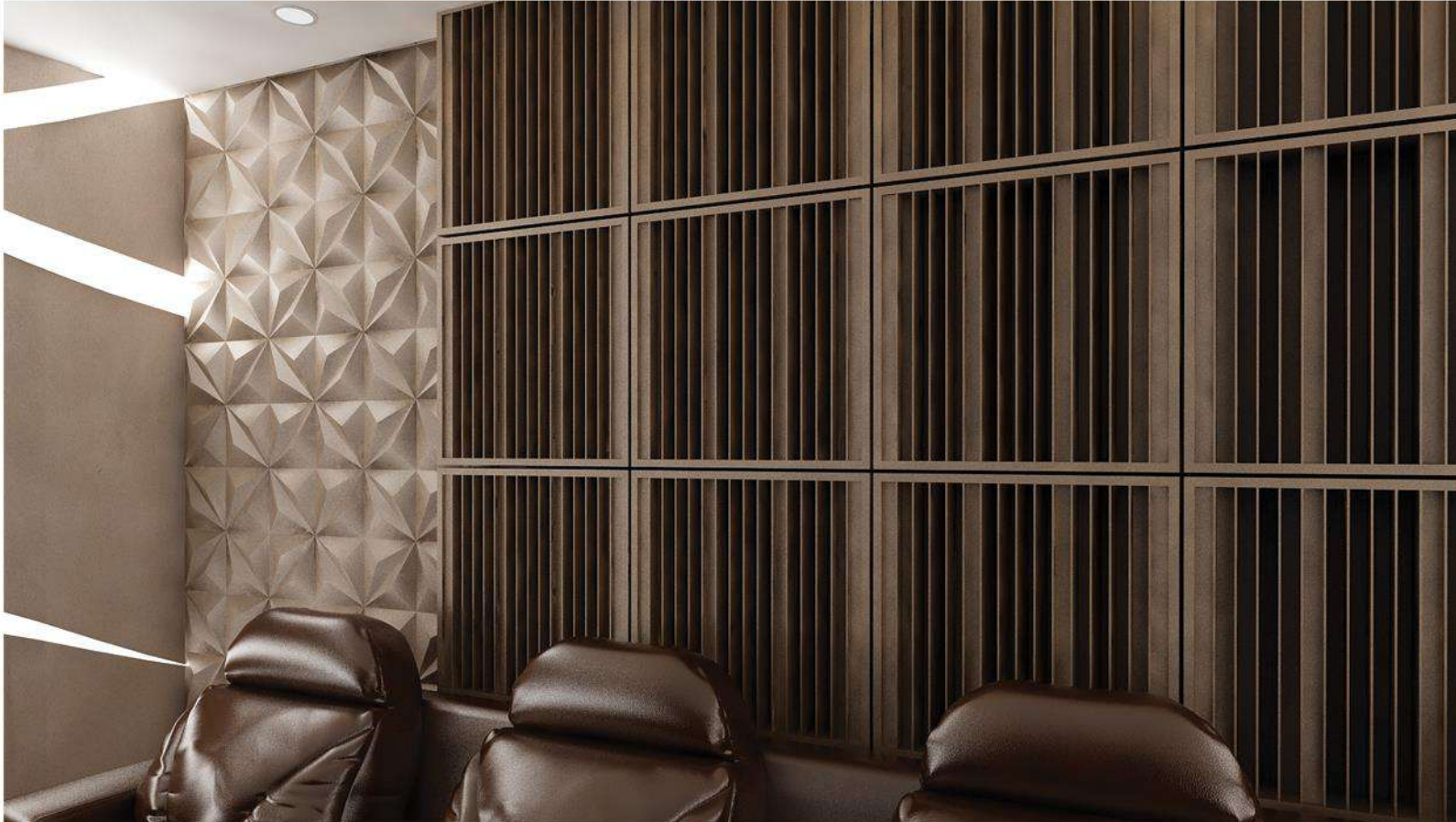

Acoustic Class = Diffuser  
Diffusion range: 1000 Hz to 7000 Hz.  
Finishes: Wood | Solid | Metallic

Installation systems:

Clip

Optimus diffusers are one-dimensional diffusers designed to scatter sound waves in one dimension i.e. from left to right. Optimus is QRD no. 17 based design with great performance. It reduces image formation and increases the liveliness of the room thereby improving sound quality and texture. They can be easily installed on walls.



# Magnus

A one dimensional QRD

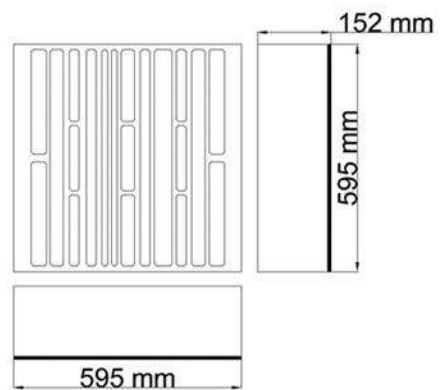

Acoustic Class = Diffuser  
Diffusion range: 1000 Hz to 7000 Hz.  
Finishes: Wood | Solid Color

Installation systems:  
Clip

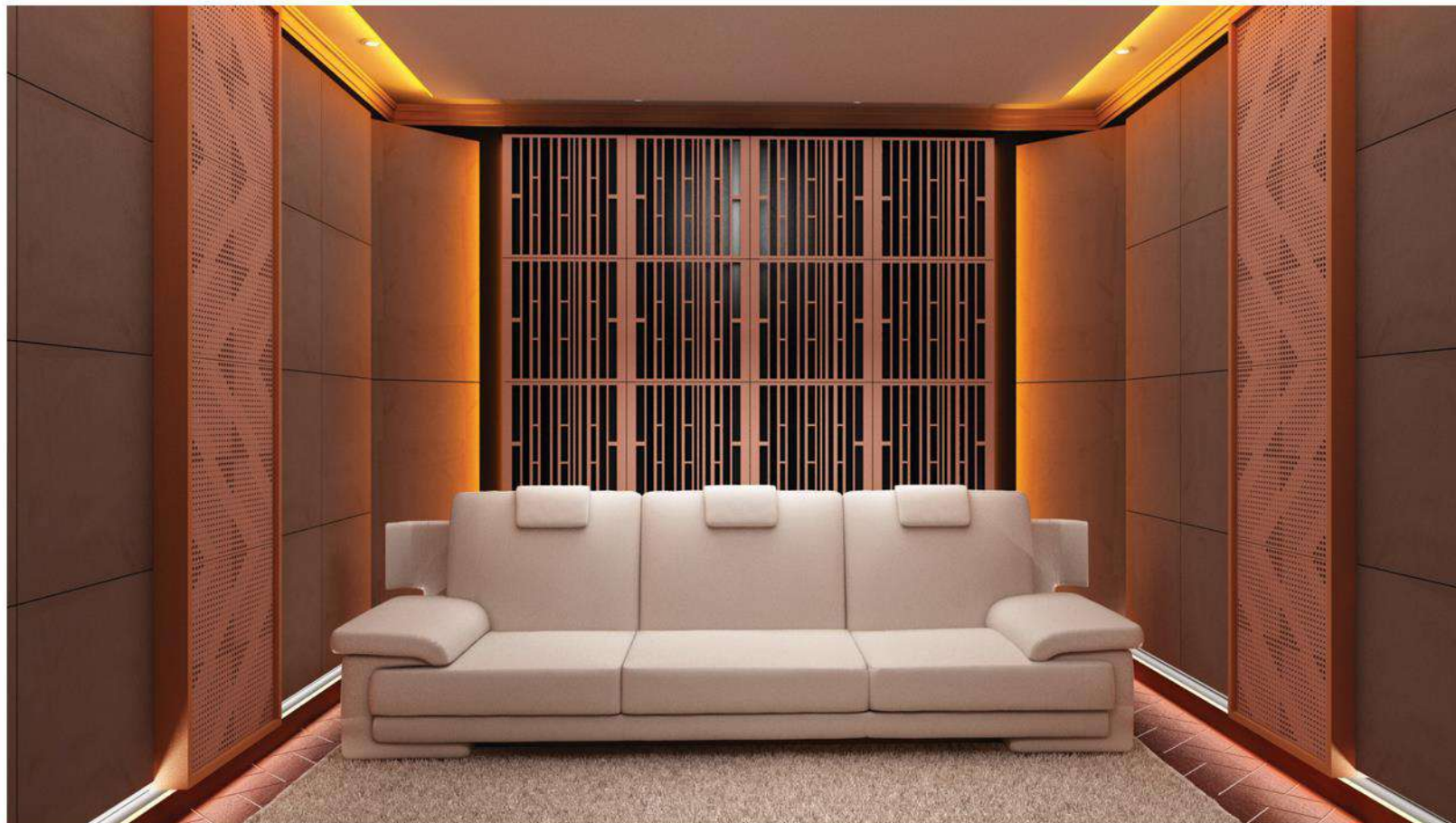
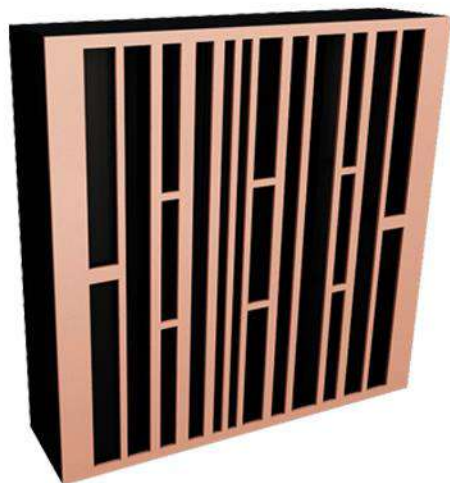

Magnus is a one dimensional diffuser with a stylish façade. It gives that extra oomph to basic diffuser design. Magnus is QRD based on No. 13. They can be easily installed on walls.

## Wave Fuser

A Gaussian Wave Diffuser.

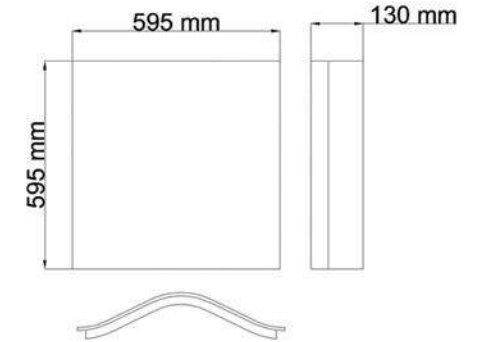

Diffusion range: 250Hz to 2500Hz.  
Acoustic Class = NRC 0.2 (125-500 Hz)  
Finishes: Wood | Solid Color

Installation systems:  
[Clip](#) | [Chain](#)

Wave diffusers are Gaussian Wave Diffusers which scatter sound very efficiently in 180°. It is an acoustic Panel Simplistic design with great performance. Wave Fuser can be easily installed on walls or ceilings.



## Polycoustic

A semi - Cylindrical Diffuser

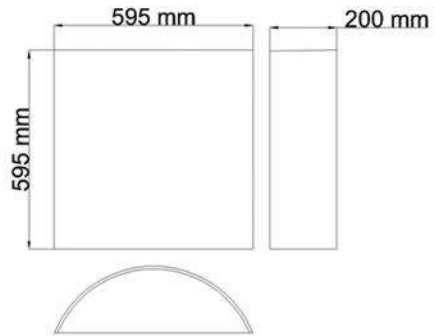

Diffusion range: 800Hz to 8000Hz.  
Acoustic Class = NRC 0.6 (125-500 Hz)  
Finishes: Wood | Standard Fabric | Micro Suede

Installation systems:

Clip | Chain

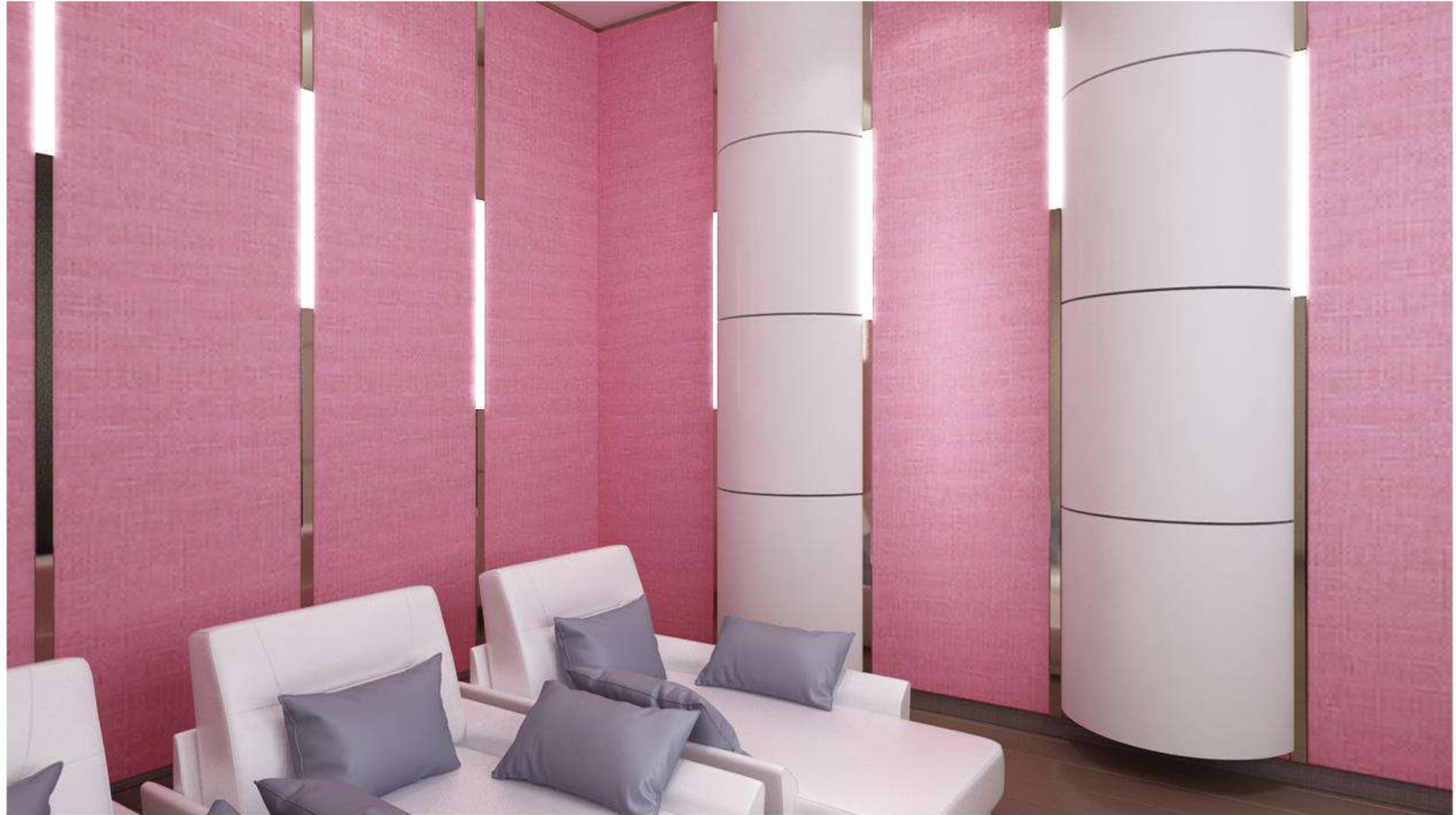

Polycoustic diffusers are semi-cylindrical diffusers designed to scatter sound waves at 180 degrees to reduce image formation and increase liveliness of room thereby improving sound quality and texture. The diffuser is backed with absorbent material making it a low-mid frequency range absorber. Simplistic design with great performance.

## Suede Fabric

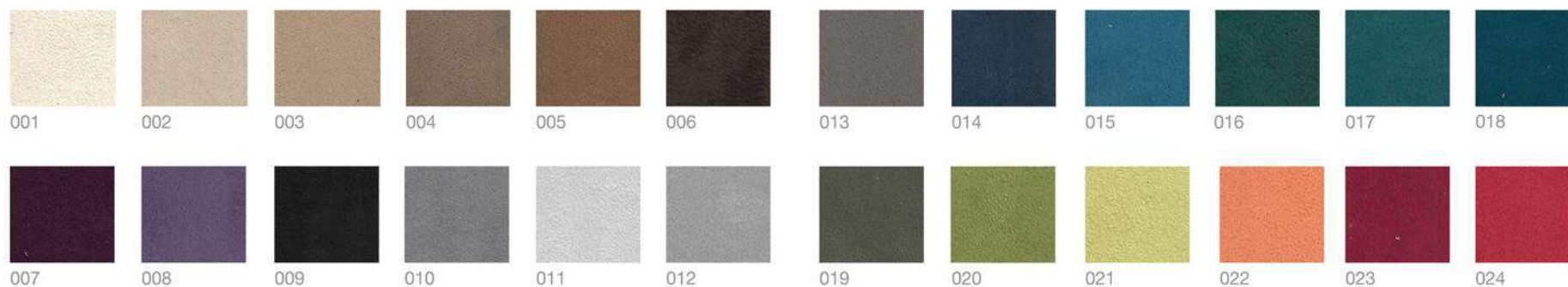

## Polyester Tweed



## Weave Fabric



### Classic Weave Fabric



### Wood Finish



### Metallic



### Solid Finish-Glossy



### Solid Finish - Matte



## Cleat Fixing System

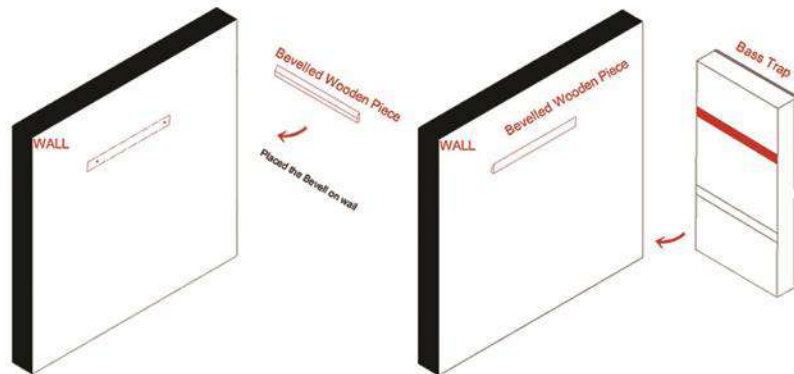

**Step 01:**  
Place the bevelled wooden piece of wall and level it with the help of level meter. Mark the holes for screwing the piece, drill and fix the piece. Now hold the bass trap with bevel support upside and just place it on top of the wall wooden piece.

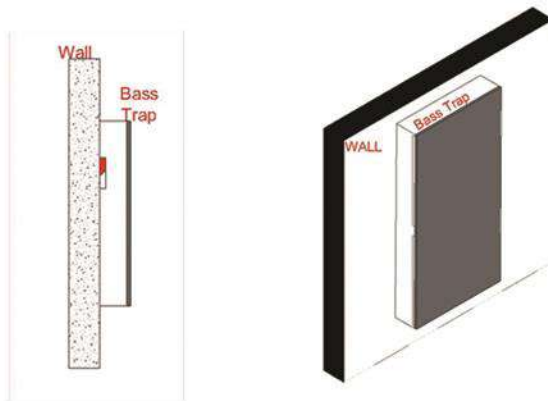

**Step 02:**  
The bass trap will hang as shown side on the wooden piece.

## Impaler Fixing System

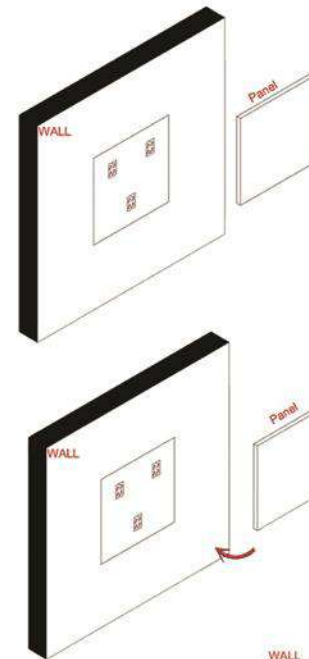

**Step 01:**  
Use a bubble level to make a straight pencil line where the top of the pencil will be, measure along this line carefully mark where the corner of each panel will be. If you are planning to space panel.

**Step 02:**  
Hold the surface impaler clips up to the wall and mark the holes for screwing. Precise mounting is not necessary. Impaler clips can be located anywhere within the panel space.

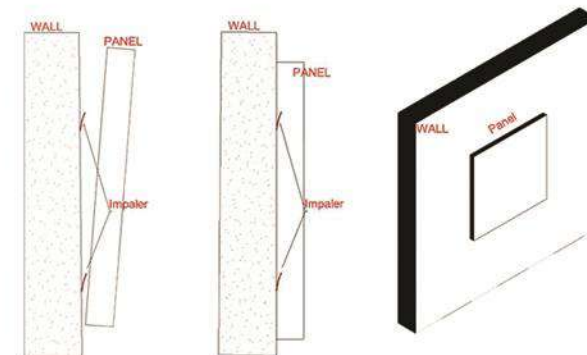

**Step 03:**  
Tilt the panel so the top edge is touching the wall. Carefully line it up on the straight line and edge marks you made in step 01. Once you have lined up the panel squarely, bring the back of the panel in contact with all the impaler tips. Apply pressure in and down onto the clips. The panel will slide onto the impaler and sink down about 1 inch. If alignment is off, the panel may be nudged up to 1/4<sup>th</sup> inch to make it level.

## Grid/Clamp Fixing System

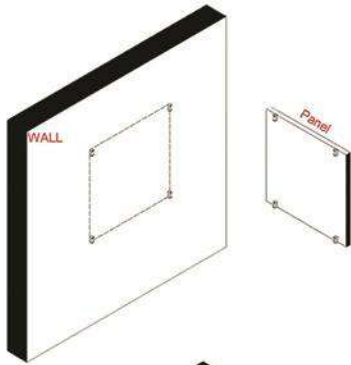

Place the panel on the wall and mark its edges. Screw the clamps on the wall inside the marking and on the panel further inside to give margin for shifting.



Place the rods between the clamps on wall as shown in figure.



Now push the panel with clamp onto the rods as shown in figure and fix the panel.

## Glue Fixing System

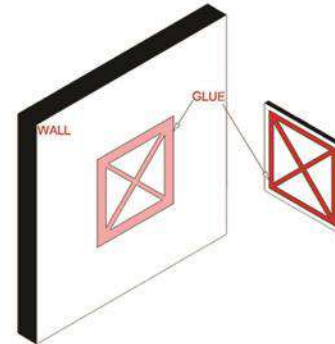

Hold the panel against wall, with the help of level meter straighten it. With the help of pencil mark the edges. Apply Glue on the back of the acoustic panel and of wall as shown.

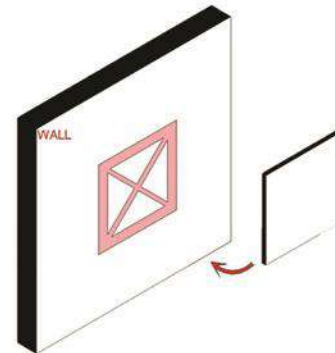

Apply the acoustic panel on the wall surface. Remove the acoustic panel slightly from the wall surface during the 15 seconds curing time.



Apply the acoustic panel on the surface and hold for a minute and ensure the panel stays fixed where installed.



Ultracoustic

We look forward to helping you create your perfect high performance acoustic environment.

---

**You can reach us at:**

- ✉ [info@ultracousticin.com](mailto:info@ultracousticin.com)
- 🌐 [www.ultracousticin.com](http://www.ultracousticin.com)
- 📘 [facebook.com/ultracoustic](https://facebook.com/ultracoustic)
- 📷 [instagram.com/ultracoustic](https://instagram.com/ultracoustic)